



Owner's Manual

Original Instructions

Split Air Conditioner

Thank you for choosing our product. Please read this Owner's Manual carefully before operation and retain it for future reference. If you have lost the Owner's Manual, please contact the local agent or visit www.unitedappliances.com for the electronic version.

NOTE : Actual product may be different from graphics, please refer to actual products.

CONTENTS

Safety precautions	01
Parts name	05
Installation notice	06
Installation of outdoor unit	08
Test and operation	10
Configuration of connection pipe	11
Manufacturer's Limited Warranty	14

**THIS MANUAL IS INTENDED
FOR THE FOLLOWING MODELS:**

UAWH09-AD3D1 | UAWH09-DD3D1

UAWH12-AD3D1 | UAWH12-DD3D1

UAWH18-DD3D1 | UAWH24-DD3D1

UAWH30-DD3D1 | UAWH36-DD3D1



Explanation of Symbols

WARNING

This symbol indicates the possibility of death or serious injury.

CAUTION

This symbol indicates the possibility of injury or damage to property.

NOTICE

Indicates important but not hazard-related information, used to indicate risk of property damage.

Exception Clauses

Manufacturer will bear no responsibilities when personal injury or property loss is caused by the following reasons.

1. Damage the product due to improper use or misuse of the product;
2. Alter, change, maintain or use the product with other equipment without abiding by the instruction manual of manufacturer;
3. After verification, the defect of product is directly caused by corrosive gas;
4. After verification, the defects are due to improper operation during transportation of product;
5. Operate, repair, maintain the unit without abiding by instruction manual or related regulations;
6. After verification, the problem or dispute is caused by the quality specification or performance of parts and components that produced by other manufacturers;
7. The damage is caused by natural calamities, bad using environment or force majeure.

If it needs to install, move or maintain the air conditioner, please contact dealer or local service center to conduct it at first. Air conditioner must be installed, moved or maintained by appointed unit. Otherwise, it may cause serious damage or personal injury or death.

When refrigerant leaks or requires discharge during installation, maintenance, or disassembly, it should be handled by certified professionals or otherwise in compliance with local laws and regulations.

This appliance is not intended for use by persons (including children) with reduced physical, sensory or mental capabilities or lack of experience and knowledge, unless they have been given supervision or instruction concerning use of the appliance by a person responsible for their safety.

Children should be supervised to ensure that they do not play with the appliance.

FCC WARNING

WARNING: Changes or modifications to this unit not expressly approved by the party responsible for compliance could void the user's authority to operate the equipment.

FCC STATEMENT

This device complies with Part 15 of the FCC Rules. Operation is subject to the following two conditions :

(1) this device may not cause harmful interference, and (2) this device must accept any interference received, including interference that may cause undesired operation.

NOTE: This equipment has been tested and found to comply with the limits for a Class B digital device, pursuant to part 15 of the FCC Rules. These limits are designed to provide reasonable protection against harmful interference in a residential installation. This equipment generates, uses and can radiate radio frequency energy and, if not installed and used in accordance with the instructions, may cause harmful interference to radio communications.

However, there is no guarantee that interference will not occur in a particular installation. If this equipment does cause harmful interference to radio or television reception, which can be determined by turning the equipment off and on, the user is encouraged to try to correct the interference by one or more of the following measures:

- Reorient or relocate the receiving antenna.
- Increase the separation between the equipment and receiver.
- Connect the equipment into an outlet on a circuit different from that to which the receiver is connected.
- Consult the dealer or an experienced radio/TV technician for help.

IC STATEMENT

This device complies with Industry Canada licence exempt RSS standard(s). Operation is subject to the following two conditions: (1) this device may not cause interference, and (2) this device must accept any interference, including interference that may cause undesired operation of the device.

Le présent appareil est conforme aux CNR d'Industrie Canada applicables aux appareils radio exempts de licence. L'exploitation est autorisée aux deux conditions suivantes : (1) l'appareil ne doit pas produire de brouillage, et (2) l'utilisateur de l'appareil doit accepter tout brouillage radioélectrique subi, même si le brouillage est susceptible d'en compromettre le fonctionnement.



IC STATEMENT

This equipment complies with FCC's and IC's RF radiation exposure limits set forth for an uncontrolled environment. The antenna(s) used for this transmitter must be installed and operated to provide a separation distance of at least 20 cm from all persons and must not be collocated or operating in conjunction with any other antenna or transmitter. Installers must ensure that 20cm separation distance will be maintained between the device (excluding its handset) and users.

Cet appareil est conforme aux limites d'exposition au rayonnement RF stipulées par la FCC et l'IC pour une utilisation dans un environnement non contrôlé. Les antennes utilisées pour cet émetteur doivent être installées et doivent fonctionner à au moins 20 cm de distance des utilisateurs et ne doivent pas être placées près d'autres antennes ou émetteurs ou fonctionner avec ceux-ci. Les installateurs doivent s'assurer qu'une distance de 20 cm sépare l'appareil (à l'exception du combiné) des utilisateurs.



Safety precautions



WARNING

Installation

- Installation or maintenance must be performed by qualified professionals.
- The appliance shall be installed in accordance with national wiring regulations.
- According to the local safety regulations, use qualified power supply circuit and circuit breaker.
- All wires of indoor unit and outdoor unit should be connected by a professional. Be
- sure to cut off the power supply before proceeding any work related to electricity and safety.
- Make sure the power supply matches with the requirement of air conditioner.
- Unstable power supply or incorrect wiring may result in electric shock, fire hazard or malfunction. Please install proper power supply cables before using the air conditioner.
- The grounding resistance

should comply with national electric safety regulations.

- Air Conditioner should be properly grounded. Incorrect grounding may cause electric shock.
- Do not put through the power before finishing installation.
- Do install the circuit breaker. If not, it may cause malfunction.
- An all-pole disconnection switch having a contact separation of at least 3mm in all poles should be connected in fixed wiring.
- Circuit breaker should be included magnet buckle and heating buckle function. It can protect the overload and circuit-short.
- Installation must be performed in accordance with the requirement of NEC and CEC by authorized personnel only.

Safety precautions



CAUTION

Installation

- Instructions for installation and use of this product are provided by the manufacturer.
- Select a location which is out of reach for children and far away from animals or plants. If it is unavoidable, please add the fence for safety purpose.
- The indoor unit should be installed close to the wall.
- Don't use unqualified power cord.
- If the length of power connection wire is insufficient, please contact the supplier for a new one.
- The appliance must be positioned so that the plug is accessible.
- For the air conditioner with plug, the plug should be reachable after finishing installation.
- For the air conditioner without plug, a circuit breaker must be installed in the

line.

- The yellow-green wire in air conditioner is grounding wire, which can't be used for other purposes.
- The air conditioner is the first class electric appliance. It must be properly grounded with specialized grounding device by a professional. Please make sure it is always ground-ed effectively, otherwise it may cause electric shock.
- The temperature of refrigerant circuit will be high, please keep the interconnection cable away from the copper tube.

Safety precautions



WARNING

Operation and Maintenance

- This appliance can be used by children aged from 8 years and above and persons with reduced physical, sensory or mental capabilities or lack of experience and knowledge if they have been given supervision or instruction concerning use of the appliance in a safe way and understand the hazards involved.
- Children shall not play with the appliance.
- Cleaning and user maintenance shall not be made by children without supervision.
- If the supply cord is damaged, it must be replaced by the manufacturer, its service agent or similarly qualified persons in order to avoid a hazard.
- Do not connect air conditioner to multi-purpose

- socket. Otherwise, it may cause fire hazard.
- Do disconnect power supply when cleaning air conditioner. Otherwise, it may cause electric shock.
- Do not wash the air conditioner with water to avoid electric shock.
- Do not spray water on indoor unit. It may cause electric shock or malfunction.
- Do not repair air conditioner by yourself. It may cause electric shock or damage. Please contact dealer when you need to repair air conditioner.
- After removing the filter, do not touch fins to avoid injury.
- Do not extend fingers or objects into air inlet or air outlet. It may cause personal injury or damage.

Safety precautions



CAUTION

Operation and Maintenance

- Do not spill water on the remote controller, otherwise the remote controller may be broken.
- Do not use fire or hair dryer to dry the filter to avoid deformation or fire hazard.
- Do not block air outlet or air inlet. It may cause malfunction.
- Do not step on top panel of outdoor unit, or put heavy objects. It may cause damage or personal injury.
- When below phenomenon occurs, please turn off air conditioner and disconnect power immediately, and then contact the dealer or qualified professionals for service.
 - Power cord is overheating or damaged.
 - There's abnormal sound during operation.
 - Circuit breaker trips off frequently.

- Air conditioner gives off burning smell.
- Indoor unit is leaking.

Parts name

Outdoor Unit

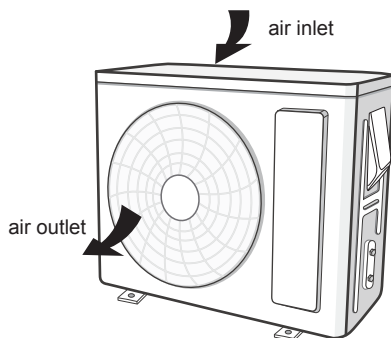

NOTE

- Actual product may be different from above graphics, please refer to actual product.

Installation notice

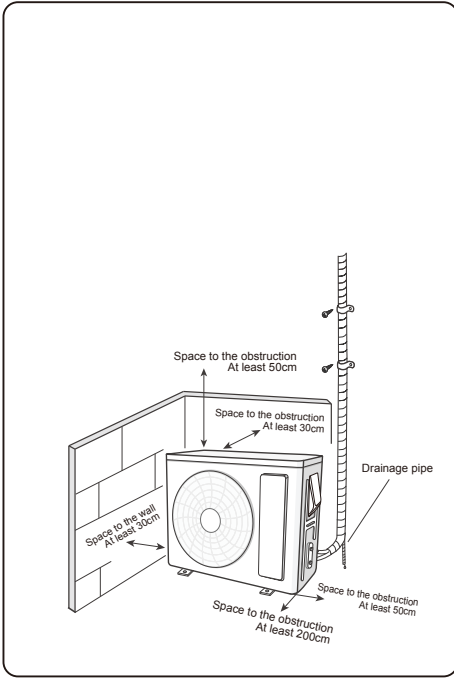

■ Safety precautions for installing and relocating the unit

To ensure safety, please be mindful of the following precautions.

⚠ WARNING

- **When installing or relocating the unit, be sure to keep the refrigerant circuit free from air or substances other than the specified refrigerant.**
Any presence of air or other foreign substance in the refrigerant circuit will cause system pressure rise or compressor rupture, resulting in injury.
- **When installing or moving this unit, do not charge the refrigerant which is not comply with that on the nameplate or unqualified refrigerant.**
Otherwise, it may cause abnormal operation, wrong action, mechanical malfunction or even serious safety accident.
- **When refrigerant needs to be recovered during relocating or repairing the unit, be**

⚠ WARNING

sure that the unit is running in cooling mode. Then, fully close the valve at high pressure side (liquid valve). About 30-40 seconds later, fully close the valve at low pressure side (gas valve), immediately stop the unit and disconnect power. Please note that the time for refrigerant recovery should not exceed 1 minute.

If refrigerant recovery takes too much time, air may be sucked in and cause pressure rise or compressor rupture, resulting in injury.

- **During refrigerant recovery, make sure that liquid valve and gas valve are fully closed and power is disconnected before detaching the connection pipe.**

If compressor starts running when stop valve is open and connection pipe is not yet connected, air will be sucked in and cause pressure rise or compressor rupture, resulting in injury.

- **When installing the unit, make sure that connection pipe is securely connected before the compressor starts running.**

If compressor starts running when stop valve is open and connection pipe is not yet connected, air will be sucked in and cause pressure rise or compressor rupture, resulting in injury.

- **Prohibit installing the unit at the place where there may be leaked corrosive gas or flammable gas.**

If there is leaked gas around the unit, it may cause explosion and other accidents.

- **Do not use extension cords for electrical connections. If the electric wire is not long enough, please contact a local service center authorized and ask for a proper electric wire.**
Poor connections may lead to electric shock or fire.

- **Use the specified types of wires for electrical connections between the indoor and outdoor units. Firmly clamp the wires so that their terminals receive no external stresses.**
Electric wires with insufficient capacity, wrong wire connections and insecure wire terminals may cause electric shock or fire.

■ Tools for installation

- | | | |
|-----------------|--------------------|-------------------------|
| ① Level meter | ⑦ Open-end wrench | ⑫ Universal meter |
| ② Screw driver | ⑧ Pipe cutter | ⑬ Inner hexagon spanner |
| ③ Impact drill | ⑨ Leakage detector | ⑭ Measuring tape |
| ④ Drill head | ⑩ Vacuum pump | |
| ⑤ Pipe expander | ⑪ Pressure meter | |
| ⑥ Torque wrench | | |

NOTICE

- Please contact the local agent for installation.
- Don't use unqualified power cord.

■ Selection of installation location

Basic requirement

Installing the unit in the following places may cause malfunction. If it is unavoidable, please consult the local dealer:

- 1.The place with strong heat sources, vapors, flammable or explosive gas, or volatile objects spread in the air.
- 2.The place with high-frequency devices (such as welding machine, medical equipment).
- 3.The place near coast area.
- 4.The place with oil or fumes in the air.
- 5.The place with sulfureted gas.
- 6.Other places with special circumstances.
- 7.The appliance shall not be installed in the laundry.
- 8.It's not allowed to be installed on the unstable or motive base structure (such as truck) or in the corrosive environment (such as chemical factory).

Outdoor unit

- 1.Select a location where the noise and outflow air emitted by the outdoor unit will not affect neighborhood.
- 2.The location should be well ventilated and dry, in which the outdoor unit won't be exposed directly to sunlight or strong wind.
- 3.The location should be able to withstand the weight of outdoor unit.
- 4.Make sure that the installation follows the requirement of installation dimension diagram.
- 5.Select a location which is out of reach for children and far away from animals or plants. If it is unavoidable, please add the fence for safety purpose.

Safety precaution

- 1.Must follow the electric safety regulations when installing the unit.
- 2.According to the local safety regulations, use qualified power supply circuit and air switch.
- 3.Make sure the power supply matches with the requirement of air conditioner. Unstable power supply or incorrect wiring or malfunction. Please install proper power supply cables before using the air conditioner.
- 4.Properly connect the live wire, neutral wire and grounding wire of power socket.
- 5.Be sure to cut off the power supply before proceeding any work related to electricity and safety.
- 6.safety. Do not put through the power before finishing installation.
- 7.If the supply cord is damaged, it must be replaced by the manufacturer, its service agent or similarly qualified persons in order to avoid a hazard.

■ Requirements for electric connection

- 8.The temperature of refrigerant circuit will be high, please keep the interconnection cable away from the copper tube.
- 9.The appliance shall be installed in accordance with national wiring regulations.
- 10.Installation must be performed in accordance with the requirement of NEC and CEC by authorized personnel only.

Grounding requirement

- 1.The air conditioner is the first class electric appliance. It must be properly grounded with specialized grounding device by a professional. Please make sure it is always grounded effectively, otherwise it may cause electric shock.
- 2.The yellow-green wire in air conditioner is grounding wire, which can't be used for other purposes.
- 3.The grounding resistance should comply with national electric safety regulations.
- 4.The appliance must be positioned so that the plug is accessible.
- 5.An all-pole disconnection switch having a contact separation of at least 3mm in all poles should be connected in fixed wiring.

Installation of outdoor unit

Step 1:

Fix the support of outdoor unit (select it according to the actual installation situation)

1. Select installation location according to the house structure.
2. Fix the support of outdoor unit on the selected location with expansion screws.

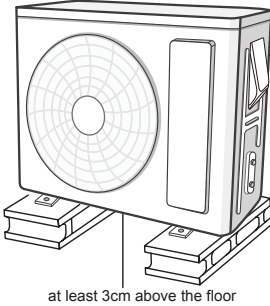

NOTICE

- Take sufficient protective measures when installing the outdoor unit.
- Make sure the support can withstand at least four times of the unit weight.
- The outdoor unit should be installed at least 3cm above the floor in order to install drain joint. (for the model with heating tube, the installation height should be no less than 20cm.)
- For the unit with cooling capacity of 2300W~5000W, 6 expansion screws are needed; for the unit with cooling capacity of 6000W~8000W, 8 expansion screws are needed; for the unit with cooling capacity of 10000W~16000W, 10 expansion screws are needed.

Step 2:

Install drain joint (only for some models)

1. Connect the outdoor drain joint into the hole on the chassis, as shown in the picture below.
2. Connect the drain hose into the drain vent.

NOTICE

- As for the shape of drainage joint, please refer to the current product. Do not install the drainage joint in the severe cold area. Otherwise, it will be frosted and then cause malfunction.

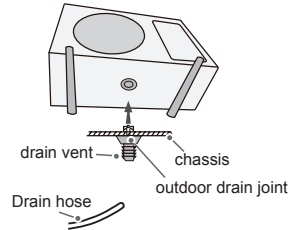

Step 3:

Fix outdoor unit

1. Place the outdoor unit on the support.
2. Fix the foot holes of outdoor unit with bolts.

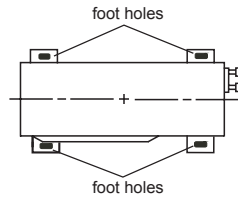

Step 4:

Connect indoor and outdoor pipes

1. Remove the screw on the right handle of outdoor unit and then remove the handle.

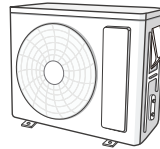

2. Remove the screw cap of valve and aim the pipe joint at the bellmouth of pipe.

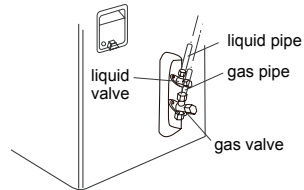

3. Pretighten the union nut with hand.

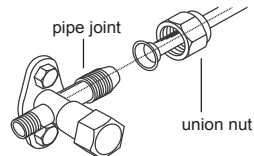

4. Tighten the union nut with torque wrench by referring to the sheet below.

Hex nut diameter	Tightening torque(N·m)
1/4"	15~20
3/8"	30~40
1/2"	45~55
5/8"	60~65
3/4"	70~75

Step 5:
Connect outdoor electric wire

1. Remove the wire clip; connect the power connection wire and signal control wire (only for cooling and heating unit) to the wiring terminal according to the color; fix them with screws.

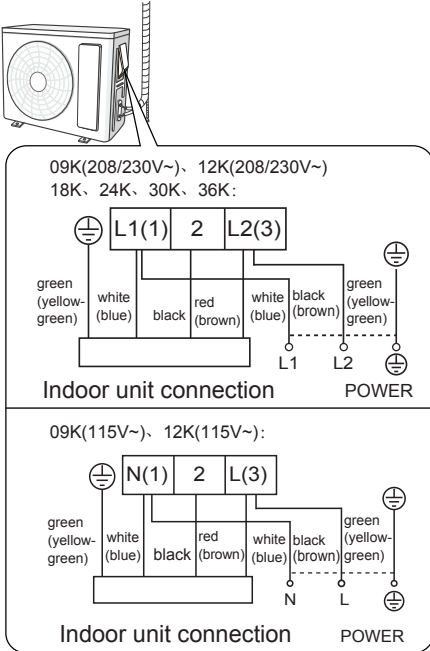

NOTICE

• The wiring board is for reference only, please refer to the actual one.

2. Fix the power connection wire and signal control wire with wire clip (only for cooling and heating unit).

NOTICE

• After tighten the screw, pull the power cord slightly to check if it is firm.
• Never cut the power connection wire to prolong or shorten the distance.

Step 6:
Neaten the pipes

1. The pipes should be placed along the wall, bent reasonably and hidden possibly.
Min. semidiameter of bending the pipe is 10cm.
2. If the outdoor unit is higher than the wall hole, you must set a U-shaped curve in the pipe before pipe goes into the room, in order to prevent rain from getting into the room.

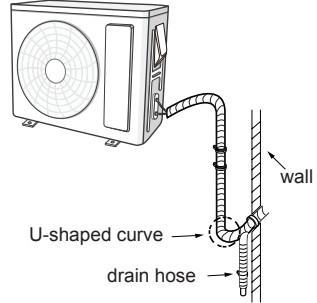

NOTICE

• The through-wall height of drain hose should not be higher than the outlet pipe hole of indoor unit.

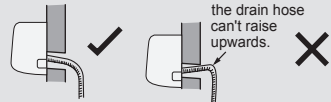

• The water outlet can't be placed in water in order to drain smoothly.

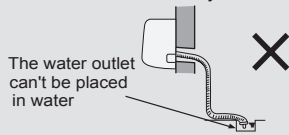

• Slant the drain hose slightly downwards. The drain hose can't be curved, raised and fluctuant, etc.

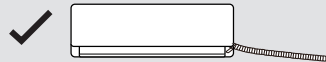

✗ The drain hose can't be fluctuant

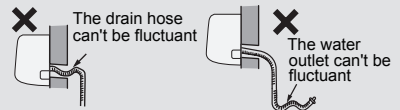

Test and operation

Use vacuum pump

1. Remove the valve caps on the liquid valve and gas valve and the nut of refrigerant charging vent.
2. Connect the charging hose of piezometer to the refrigerant charging vent of gas valve and then connect the other charging hose to the vacuum pump.
3. Open the piezometer completely and operate for 10-15min to check if the pressure of piezometer remains in -0.1MPa.
4. Close the vacuum pump and maintain this status for 1-2min to check if the pressure of piezometer remains in -0.1MPa. If the pressure decreases, there may be leakage.
5. Remove the piezometer, open the valve core of liquid valve and gas valve completely with inner hexagon spanner.
6. Tighten the screw caps of valves and refrigerant charging vent.
7. Reinstall the handle.

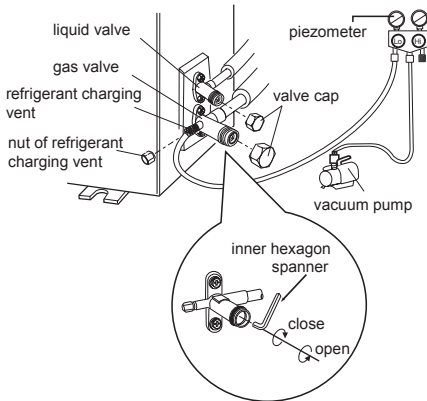

Leakage detection

1. With leakage detector:
Check if there is leakage with leakage detector.
2. With soap water:
If leakage detector is not available, please use soap water for leakage detection. Apply soap water at the suspected position and keep the soap water for more than 3min. If there are air bubbles coming out of this position, there's a leakage.

Check after installation

- Check according to the following requirement after finishing installation.

Items to be checked	Possible malfunction
Has the unit been installed firmly?	The unit may drop, shake or emit noise.
Have you done the refrigerant leakage test?	It may cause insufficient cooling(heating) capacity.
Is heat insulation of pipeline sufficient?	It may cause condensation and water dripping.
Is water drained well?	It may cause condensation and water dripping.
Is the voltage of power supply according to the voltage marked on the nameplate?	It may cause malfunction or damage the parts.
Is electric wiring and pipeline installed correctly?	It may cause malfunction or damage the parts.
Is the unit grounded securely?	It may cause electric leakage.
Does the power cord follow the specification?	It may cause malfunction or damage the parts.
Is there any obstruction in the air inlet and outlet?	It may cause insufficient cooling(heating) capacity.
The dust and sundries caused during installation are removed?	It may cause malfunction or damage the parts.
The gas valve and liquid valve of connection pipe are open completely?	It may cause insufficient cooling (heating) capacity.
Is the inlet and outlet of piping hole been covered?	It may cause insufficient cooling (heating) capacity or waste electricity.

Test operation

1. Preparation of test operation

- The client approves the air conditioner.
- Specify the important notes for air conditioner to the client.

2. Method of test operation

- Put through the power, press ON/OFF button on the remote controller to start operation.
- Press MODE button to select AUTO, COOL, DRY, FAN and HEAT to check whether the operation is normal or not.
- If the ambient temperature is lower than 16 C, the air conditioner can't start cooling.

Configuration of connection pipe

- Standard length of connection pipe: 5m, 7.5m, 8m.
- Min. length of connection pipe is 3m.
- Max. length of connection pipe is shown as below.

Max. length of connection pipe

Cooling capacity	Max. length of connection pipe(m)
5000Btu/h (1465W)	15
7000Btu/h (2051W)	15
9000Btu/h (2637W)	15
12000Btu/h (3516W)	20
18000Btu/h (5274W)	25
24000Btu/h (7032W)	25
28000Btu/h (8204W)	30
36000Btu/h (10548W)	30
42000Btu/h (12306W)	30
48000Btu/h (14064W)	30

- The additional refrigerant oil and refrigerant charging required after prolonging connection pipe.
 - After the length of connection pipe is prolonged for 10m at the basis of standard length, you should add 5ml of refrigerant oil for each additional 5m of connection pipe.
 - The calculation method of additional refrigerant charging amount(on the basis of liquid pipe):
 Additional refrigerant charging amount = prolonged length of liquid pipe × additional refrigerant charging amount per meter
 - Basing on the length of standard pipe, add refrigerant according to the requirement as shown in the table. The additional refrigerant charging amount per meter is different according to the diameter of liquid pipe. See the following sheet.

Additional refrigerant charging amount for R22, R407C, R410A and R134a

Outdoor unit throttle	Cooling and heating(g/m)	Cooling only(g/m)	Piping size	
	Gas pipe		Liquid pipe	
20	15	15	3/8" or 1/2"	1/4"
			5/8" or 3/4"	1/4" or 3/8"
50	30	60	3/4" or 7/8"	1/2"
			1" or 1 1/4"	5/8"
120	250	350	-	3/4"
			-	7/8"

Pipe expanding method

NOTICE

Improper pipe expanding is the main cause of refrigerant leakage. Please expand the pipe according to the following steps:

A: Cut the pipe

- Confirm the pipe length according to the distance of indoor unit and outdoor unit.
- Cut the required pipe with pipe cutter.

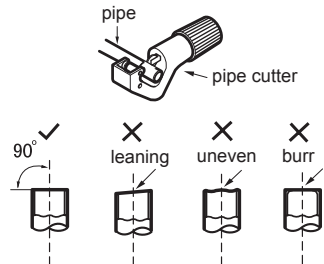

B: Remove the burrs

- Remove the burrs with shaper and prevent the burrs from getting into the pipe.

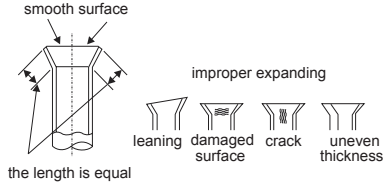
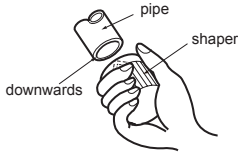

C: Put on suitable insulating pipe

D: Put on the union nut

- Remove the union nut on the indoor connection pipe and outdoor valve; install the union nut on the pipe.

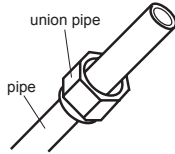

Working temperature range

- UAWH09-AD3D1
- UAWH09-DD3D1
- UAWH12-AD3D1
- UAWH12-DD3D1
- UAWH18-DD3D1
- UAWH24-DD3D1

E: Expand the port

- Expand the port with expander.

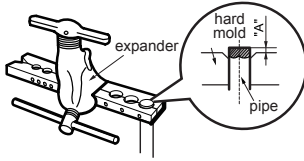

NOTICE

- "A" is different according to the diameter, please refer to the sheet below:

Outer diameter (mm)	A(mm)	
	Max	Min
Φ6 - 6.35(1/4")	1.3	0.7
Φ9 - 9.52(3/8")	1.6	1.0
Φ12-12.7(1/2")	1.8	1.0
Φ15.8-16(5/8")	2.4	2.2

	Indoor side DB/WB(C/°F)	Outdoor side DB/WB(C/°F)
Maximum cooling	26.7/19.4 (80/67)	48/23.9 (118/75)
Maximum heating	26.7/- (80/-)	24/18.3 (75/65)

NOTE

- The operating temperature range (outdoor temperature) for cooling is -18°C(0°F)~48°C(118°F); for heat pump unit is -25°C(-13°F) ~ 48°C(118°F).

F: Inspection

- Check the quality of expanding port. If there is any blemish, expand the port again according to the steps above.

UAWH09-AD3D1
 UAWH09-DD3D1
 UAWH12-AD3D1
 UAWH12-DD3D1
 UAWH18-DD3D1
 UAWH24-DD3D1
 UAWH30-DD3D1
 UAWH36-DD3D1

	Indoor side DB/WB(°C/°F)	Outdoor side DB/WB(°C/°F)
Maximum cooling	26.7/19.4 (80/67)	50/24 (122/75)
Maximum heating	26.7/- (80/-)	24/18 (75/65)

NOTE

- The operating temperature range (outdoor temperature) for cooling is -20°C (-4°F) ~ 50°C (122°F); for heat pump unit is -25°C (-13°F) ~ 50°C (122°F).

MANUFACTURER'S LIMITED WARRANTY

1.0 **WARRANTOR.** This Limited Warranty is offered by Dragon Trade International Corp , 1205 Highland Avenue, National City, California 91950, ("Manufacturer") on the Products described below.

2.0 **PRODUCT.** This Limited Warranty applies to the following products, residential and commercial air conditioner units manufactured by Manufacturer, collectively ("Product").

3.0 **WHO MAY USE THIS WARRANTY .** This Limited Warranty is intended only for the benefit of original purchasers who purchase product from an authorized retailer or installer of the product in the United States on or after September 1, 2023, ("Consumer").

4.0 **WARRANTY COVERAGE .** Subject to the "Warranty Conditions, Limitations, and Exclusions" set forth hereinbelow, Manufacturer expressly warrants the Product as follows:

4.01 Manufacturer warrants the Product to be free from defects in material and workmanship as follows: for a period of ten (10) years on all parts, including the Compressor, and one (1) year on the remote controller from the date of delivery to the Consumer, ("Warranty Period"). Date of delivery to Consumer shall be the date earlier of the date the Product is delivered to the Consumer's installation contractor or the place of installation.

4.02 Manufacturer, in its sole discretion, will repair or replace, free of charge, the Product or component part thereof, which proves to be defective in materials or workmanship during the Warranty Period. Any replacement parts provided by will be of equal or greater quality than the replaced part.

4.03 All Warranty service or repairs must be performed in accordance with the provisions of the "How to Obtain Warranty Service" section set forth hereinbelow.

4.04 This Limited Warranty does NOT include labor, or any other costs incurred for service, maintenance, repair, removal, replacement, installation, compliance with local building and electrical codes; nor does it include shipping, handling, delivery or transportation cost of the Product or any replacement parts thereof.

5.0 **WARRANTY CONDITIONS, LIMITATIONS, AND EXCLUSIONS .** This Limited Warranty is subject to the following conditions, limitations, and exclusions:

5.01 This Limited Warranty only applies to Products purchased after September 1, 2023.

5.02 This Limited Warranty only applies to Products purchased by original consumer purchasers who, purchase the Product from an authorized retailer or installer of the Product, and install the Product, in the United States; it does not apply to Products received through promotions, contests, giveaways, or sponsorship events.

5.03 This Limited Warranty is transferrable if, and only if, the Products is purchased through, and registered with, an authorized a dealer.

5.04 This Limited Warranty only applies to Products installed by appropriately and validly licensed contractors in accordance with: (a) all applicable codes, laws, rules, regulations, and requirements, including without limitation all applicable building permits; and (b) all manufacturer installation instructions and best industry practices; and after proper handling and best transport practices from date of purchase.

5.05 This Limited Warranty does not apply to damage resulting from or repaired by: (a) improper installation or operator error; (b) installation by non or inappropriately licensed persons firms or entities; (c) misuse, abuse, accident, or unauthorized alteration; (d) natural disaster, weather, or acts of nature; (e) animals, vermin or pests; (f) power failures, including brownouts or surges; (g) frozen or broken pipes; (h) inadequate ventilation or corrosive environments at or around the installation site; (i) inadequate maintenance, including maintenance not performed in accordance with the Product operating manual or recognized best practices; (j) ordinary wear and tear; or (k) any other conditions or acts beyond the control of Manufacturer, (l) spare parts, damaged during maintenance and repairs.

5.06 EXCEPT AS OTHERWISE PROVIDED IN THIS LIMITED WARRANTY, OR AS REQUIRED BY LAW, MANUFACTURER MAKES NO OTHER WARRANTIES OF ANY KIND WITH RESPECT TO THE PRODUCT, AND HEREBY DISCLAIMS AND EXCLUDES ALL WARRANTIES AND REMEDIES NOT EXPRESSLY PROVIDED HEREIN OR REQUIRED BY LAW, INCLUDING, BUT NOT LIMITED TO, ANY IMPLIED WARRANTIES. NO ONE IS AUTHORIZED TO CHANGE THIS LIMITED WARRANTY IN ANY RESPECT OR CREATE ANY OTHER OBLIGATION OR LIABILITY FOR MANUFACTURER IN CONNECTION WITH THE PRODUCT OR ANY UNITED APPLIANCES EQUIPMENT.

5.07 UNDER NO CIRCUMSTANCES SHALL MANUFACTURER BE LIABLE FOR ANY INDIRECT, INCIDENTAL, SPECIAL, PUNITIVE OR CONSEQUENTIAL DAMAGES, INCLUDING, BUT NOT LIMITED TO, INFRINGEMENT OF THIRD PARTY RIGHTS, LOSS OF GOODWILL, LOSS OF REVENUE OR PROFITS, WORK INTERRUPTION, SYSTEM FAILURE, DETERIORATION OF OTHER PROPERTY, COSTS OF PRODUCT REMOVAL AND REINSTALLATION, INCREASE IN THE USE OF ENERGY, LOSS OF USE, INJURY TO PERSONS OR PROPERTY ARISING OUT OF OR RELATED TO THE PRODUCT, WHETHER FOR BREACH OF WARRANTY, BREACH OF CONTRACT, TORT OR OTHERWISE, EVEN IF MANUFACTURER HAS BEEN ADVISED OF THE POSSIBILITY OF SUCH DAMAGE. IN NO EVENT SHALL MANUFACTURER'S LIABILITY EXCEED THE ACTUAL PURCHASE PRICE OF THE SYSTEM WITH RESPECT TO WHICH ANY CLAIM IS MADE.

5.08 SOME STATES DO NOT ALLOW THE EXCLUSION OR LIMITATION OF WARRANTIES OR EXCLUSIONS OR LIMITATIONS OF DAMAGES, INCLUDING INCIDENTAL OR CONSEQUENTIAL DAMAGES, SO THE ABOVE LIMITATIONS OR EXCLUSIONS MAY NOT APPLY.

5.09 This Limited Warranty does not apply to (a) service calls when no covered Product defect is identified; or (b) to explain the use and operation of the Product to the Consumer.

5.10 In the event of a Product failure, the Product should be de-energized, but otherwise should remain as-is, where-is until inspected by an authorized technician, unless there is a life/safety threat or the likelihood of resultant physical damage to other property, in which case all appropriate safety precautions should be taken by qualified persons. Absent a life/safety threat or the likelihood of resultant physical damage to other property, the failure to maintain the Product as-is, where-is as provided herein, voids the Warranty.

6.0 Product Registration

It is recommended that Consumer complete the Product Registration Card included in the original Product packaging and return it to Manufacturer or register on the Product on the manufacturer's website. Doing so will facilitate a Warranty Claim (defined hereinbelow); however, the Consumer is not required to complete and return the Product Warranty Card for his Limited Warranty to be effective.

7.0 HOW TO OBTAIN WARRANTY SERVICE

7.01 During the Warranty Period, contact the Manufacturer by email at customerservices@unitedappliances.com, or telephone at 800-691-2050, or United States mail at 1205 Highland Avenue, National City, California 91950, to notify Manufacturer of a claim under this Limited Warranty, ("Warranty Claim").

7.02 As part of the Warranty Claim, Consumer will be required to present the original purchase invoice for the Product, and completed Product registration, which shall include the name and CSLB license number of the certified installer, as well as any other reasonable documentation reflecting date of purchase and/or date of delivery of the Product to the Consumer.

7.03 Within thirty (30) days from the date the Warranty Claim is received by Manufacturer, an authorized service technician will visit the Consumer's residence to inspect the Product and determine whether the Warranty Claim is covered under this Limited Warranty.

7.04 If the Warranty Claim is covered, Manufacturer, subject to the labor and shipping limitations above, will, in its sole discretion, will repair or replace, the Product or any covered component part thereof, at no cost to the Consumer.

7.05 Consumer will be invoiced for all shipping and labor costs incurred in connection with the repair or replacement of the Product or any component part provided herein and shall pay such invoice upon receipt.

8.0 DISPUTE RESOLUTION

8.01 Agreement for Binding Arbitration. Arbitration under this Agreement is governed by the Federal Arbitration Act (9 U.S.C. §§ 1 et seq.). This Agreement applies to Consumer and Manufacturer, and their respective heirs, assigns, spouses, family members, affiliates, officers, directors, attorneys, insurers, shareholders, successors, subsidiaries and/or parent companies, and survives the termination of the Warranty Period. SUBJECT TO CONSUMER'S RIGHT TO BRING ANY CLAIM AGAINST MANUFACTURER IN A SMALL CLAIMS COURT OF

COMPETENT JURISDICTION CONSUMER AND MANUFACTURER AGREE THAT ANY DISPUTE, CLAIM OR CONTROVERSY ARISING OUT OF THIS AGREEMENT OR THE USE OF THE PRODUCT, INCLUDING ISSUES OF ARBITRABILITY, SHALL, ("DISPUTE"), AT THE OPTION OF EITHER PARTY, BE RESOLVED BY BINDING ARBITRATION BEFORE A SINGLE NEUTRAL ARBITRATOR ADMINISTERED BY JUDICIAL ARBITRATION AND MEDIATION SERVICES ("JAMS") UNDER ITS APPLICABLE ARBITRATION RULES IN EFFECT AT THE TIME THE DISPUTE ARISES. DISPUTES SHALL NOT BE RESOLVED BY COURT OR JURY TRIAL, AND CONSUMER IS WAIVING ANY RIGHT TO A COURT OR JURY TRIAL. The JAMS Policy on Consumer Arbitration and Minimum Standards of Procedural Fairness in effect at the time the Dispute arises are deemed incorporated by reference herein and shall govern the Arbitration.

The JAMS Rules and may be found at www.jamsadr.com, by searching for "JAMS Arbitration Rules" using a service such as www.Google.com or www.Yahoo.com, or by asking Manufacturer for a copy of the rules. If for any reason JAMS will not administer the arbitration, either party may apply to a court of competent jurisdiction with authority over the location where the arbitration will be conducted for appointment of a neutral Arbitrator.

The Arbitration hearing shall, unless the Parties otherwise agree in writing, be held within forty-five miles of where CONSUMER resides. Manufacturer shall pay all costs and expenses unique to arbitration, including without limitation the arbitrator's fees. The Parties shall be entitled to discovery as provided by the Federal Rules of Civil Procedure. The arbitrator must follow applicable law and may award only those remedies that would have applied had the matter been heard in court. Judgment may be entered on the arbitrator's decision in any court of competent authority.

Either Consumer or Manufacturer may apply to a court of competent authority for temporary or preliminary injunctive relief in connection with an arbitrable controversy, but only upon the ground that the award to which that party may be entitled may be rendered ineffectual without such relief.

8.02 Class, Collective, and Representative Action Waiver. This Agreement affects your ability to participate in class, collective or representative actions. Consumer and Manufacturer agree to bring any Dispute in Arbitration on an individual basis only, and not on a class, collective, or private attorney general representative basis. There will be no right or authority for any Dispute to be brought, heard or arbitrated as a class, collective, representative, or private attorney general action, or as a member in any purported class, collective, representative, or private attorney general proceeding ("Class Action Waiver"). Notwithstanding any other provision of this Agreement or the JAMS Rules, disputes regarding the validity, enforceability, or breach of the Class Action Waiver may be resolved only by a civil court of competent jurisdiction and not by an arbitrator. In any case in which (1) the dispute is filed as a class, collective, representative, or private attorney general action and (2) a civil court of competent jurisdiction finds all or part of the Class Action Waiver unenforceable, the class, collective, representative, and/or private attorney general action to that extent must be litigated in a civil court of competent jurisdiction, but the portion of the Class Action Waiver that is enforceable shall be enforced in arbitration. The Class Action Waiver shall be severable in any case in which the dispute is filed as an individual action and severance is necessary to ensure that the individual action proceeds in arbitration.

8.03 Commencing the Arbitration. All claims in arbitration are subject to the same statutes of limitations that would apply in court under applicable law. The Party bringing the claim must demand arbitration in writing and deliver the written demand by hand or first-class mail to the other party within the applicable statute of limitations period. The demand for arbitration shall include identification of the parties, a statement of the legal and factual basis of the claim(s), and a specification of the remedy sought. Any demand for arbitration shall be provided to Provider's registered agent for service of process. The arbitrator shall resolve all disputes regarding the timeliness or propriety of the demand for arbitration.

8.04 Enforcement of this Agreement. This Agreement is the full and complete agreement relating to the formal resolution of disputes covered by this Agreement and shall supersede all other agreements concerning arbitration. In the event any part of this Agreement is held unenforceable, the rest of this Agreement will be enforceable. If the Class Action Waiver in Section 2 of this Agreement is unenforceable, Manufacturer and Consumer agree that this Agreement is otherwise silent as to any Party's ability to bring a class, collective, or representative action in arbitration.

9.0 GENERAL PROVISIONS

9.01 Governing Law. This Limited Warranty and any Warranty Claim hereunder shall be governed by the laws of the State of California, unless the Consumer lives in and the Product was installed in a residence located in a different state, in which case the laws of the state of installation shall apply.

9.02 Entire Agreement. This Agreement constitutes the entire agreement between the Parties hereto pertaining to the subject matter hereof, and all prior or contemporaneous agreements, representations, or understandings by and between the Parties, whether written or oral, are superseded and merged herein.

9.03 Modification; Waiver. No supplement, amendment or modification of this Limited Warranty shall be valid or binding unless in writing and executed by an authorized officer of Manufacturer. Manufacturer shall not be deemed to have waived any provision in this Agreement, unless specifically agreed to in writing and signed authorized officer of Manufacturer. No waiver of any provision of this Limited Warranty shall be deemed to constitute a continuing waiver of that provision, nor shall it be deemed to constitute a waiver of any other provision.

9.04 Severability. Should any provision of this Agreement be declared by any court of competent jurisdiction to be illegal or invalid, the validity of the remaining parts, terms, or provisions shall not be affected thereby, and said illegal and/or invalid part, term, or provision shall be deemed not to be a part of the Agreement.

10. NOTICE TO CONSUMER

This Limited Warranty gives you specific legal rights. You may have other rights which vary from state to state.

RETURN AND EXCHANGE



If you have any issues with your product or not entirely satisfied, please visit <https://unitedappliances.com/us/returns-exchange/> or scan the QR code for all the steps.

The logo for United Appliances features a stylized 'U' on the left, composed of two thick, black, curved segments that meet at the bottom. To the right of this symbol, the words 'UNITED' and 'APPLIANCES' are stacked vertically in a bold, black, sans-serif font. A registered trademark symbol (®) is positioned at the top right of the word 'UNITED'.

UNITED[®]
APPLIANCES

Imported by

Dragon Trade International Corp.

614 5th Ave. Ste D, San Diego CA 92101-6964

Customer service: (800) 691-2050

unitedappliances.com